

1 PREPARAZIONE DELLA BARRA • PREPARE THE ARM

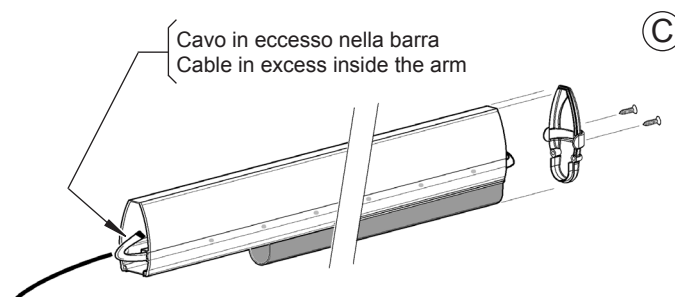

2 INSTALLARE LA BARRA • INSTALL THE ARM

B3000/5000

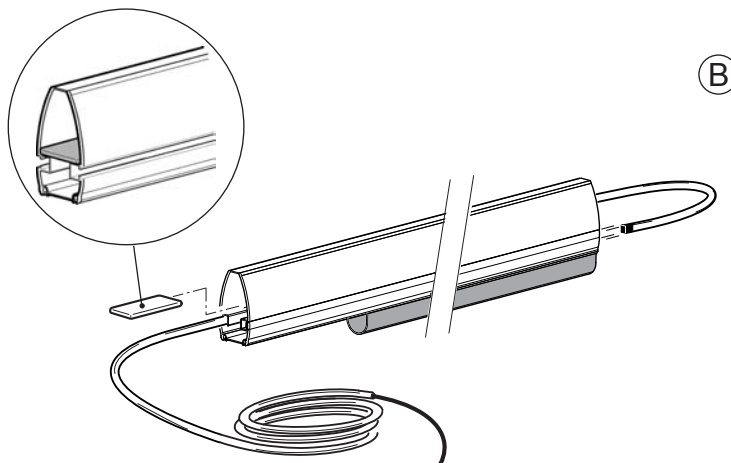
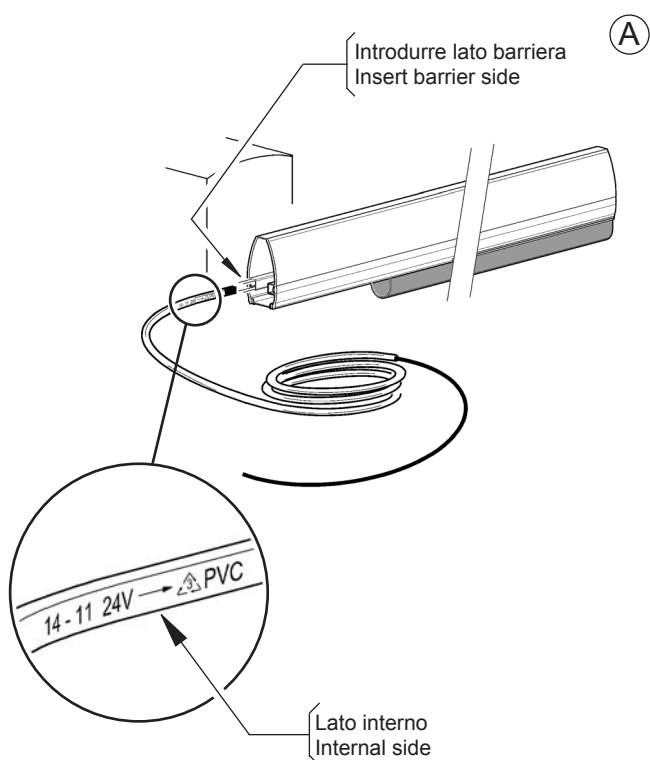
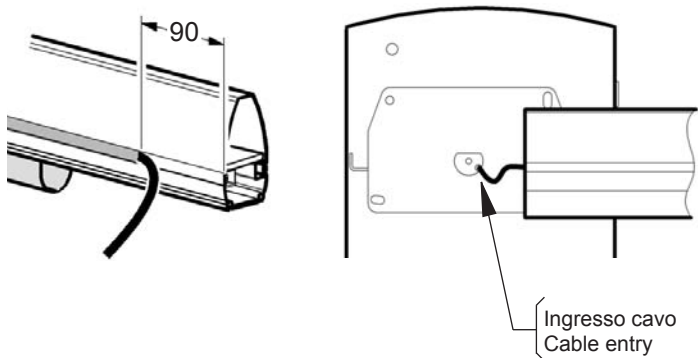

B24

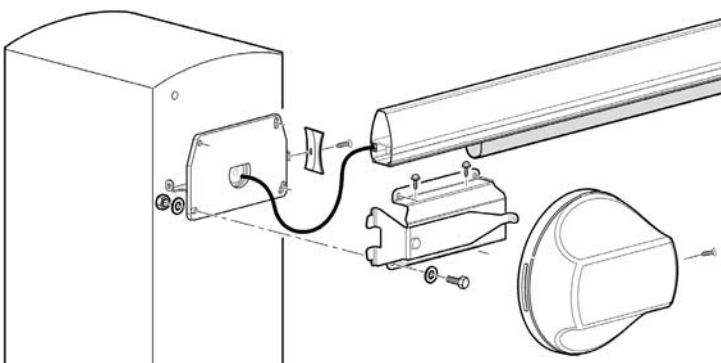
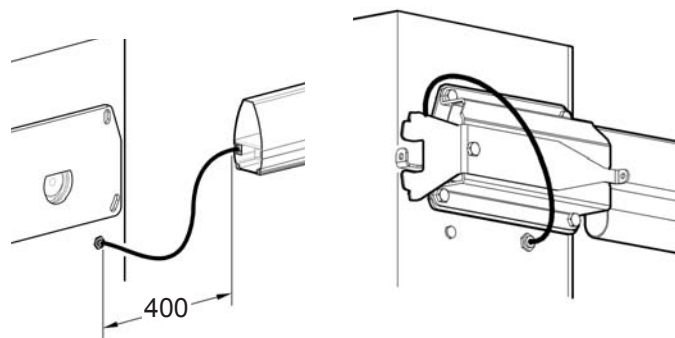

3 POSIZIONARE IL CAVO NELLA BARRIERA • PLACING THE CABLE IN THE BARRIER



BARRA DESTRA
RIGHT ARM

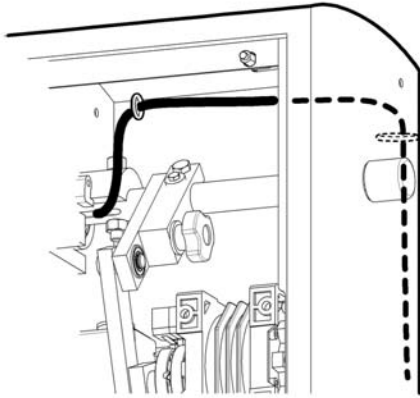

BARRA SINISTRA
LEFT ARM

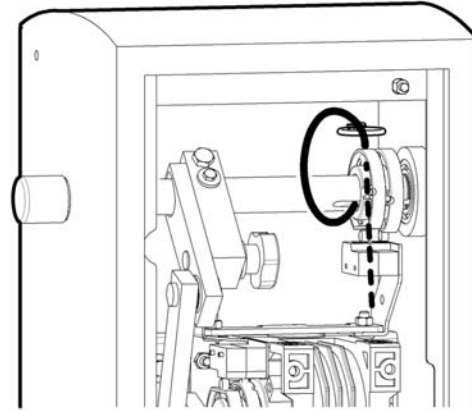

4 COLLEGAMENTI ELETTRICI • ELECTRICAL CONNECTIONS

B3000 newB24 V2.4
B5000 newB24 V2.5

SA24

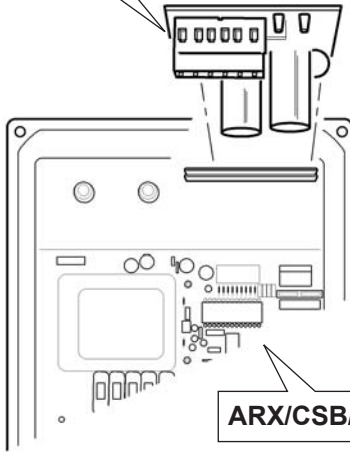

ARX/CSB/LOG-BR

B24

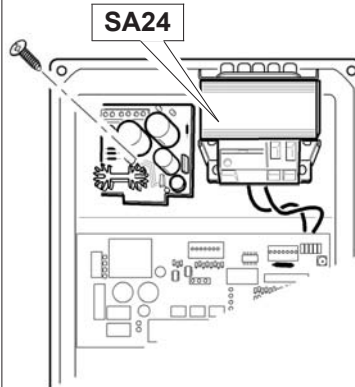

SA24

ARX

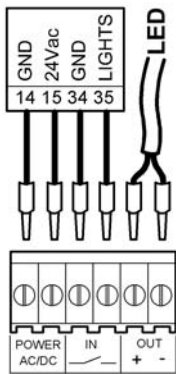

CSB

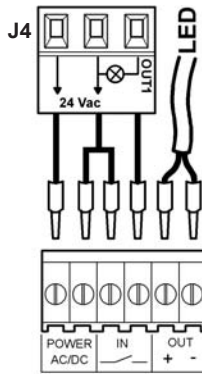

LOG-BR

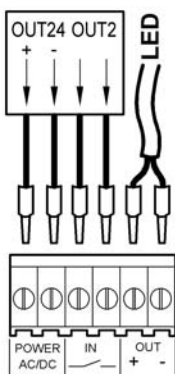

LOG-BT

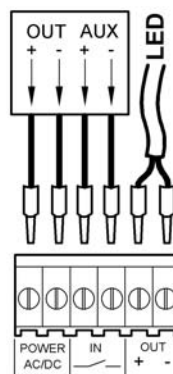

SA24

SA24

Nel caso le luci non si accendano invertire le connessioni out +/-
In case of light-off, invert the out +/- connection



- **PERICOLO!** Prima di effettuare qualsiasi intervento sull'impianto togliere l'alimentazione elettrica.
- **DANGER!** Always disconnect the electricity before attempting any work on the system.