

# KIT-LIGHT 8

Beleuchtungs-Kit für BL-LARGE  
 Kit luci per BL-LARGE  
 Light bars kit for BL-LARGE

## 1 SCHRANKENBAUM VORBEREITEN • PREPARE THE ARM • PREPARAZIONE DELLA BARRA

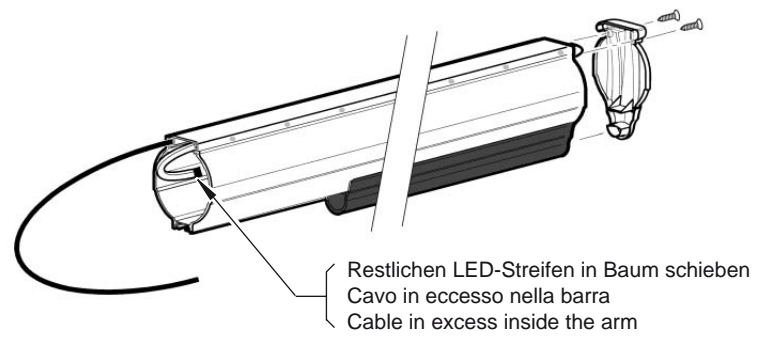
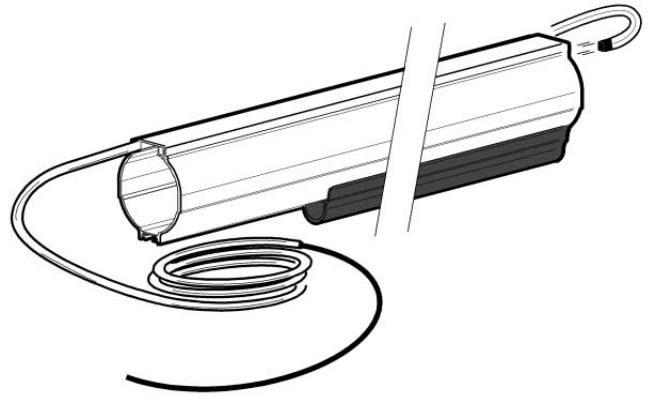
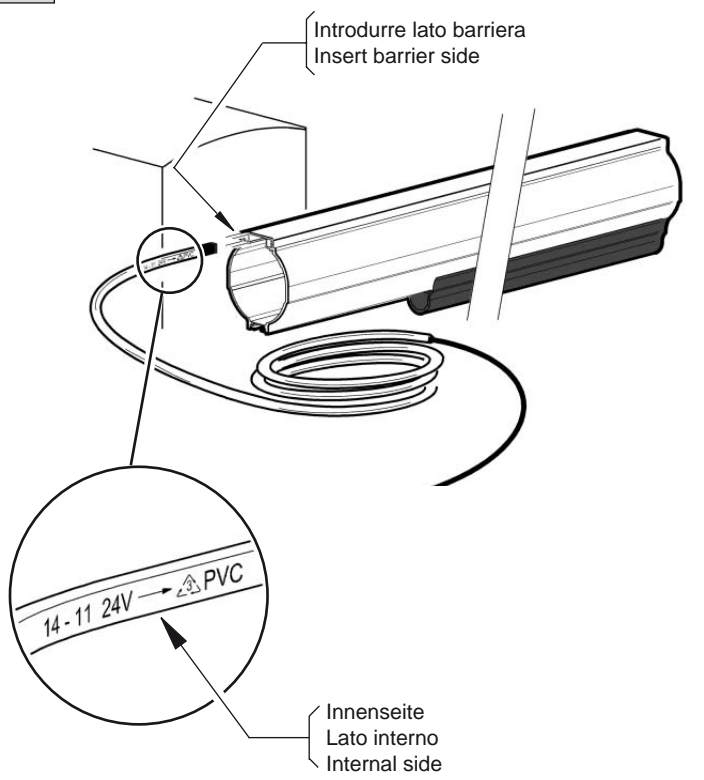

## 2 SCHRANKENBAUM MONTIEREN • INSTALLARE LA BARRA • INSTALL THE ARM

B6000 - B7000 - B8000

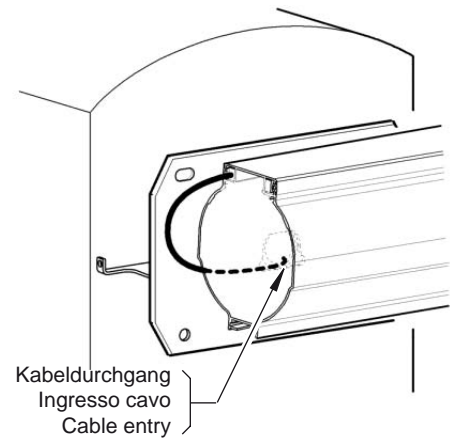
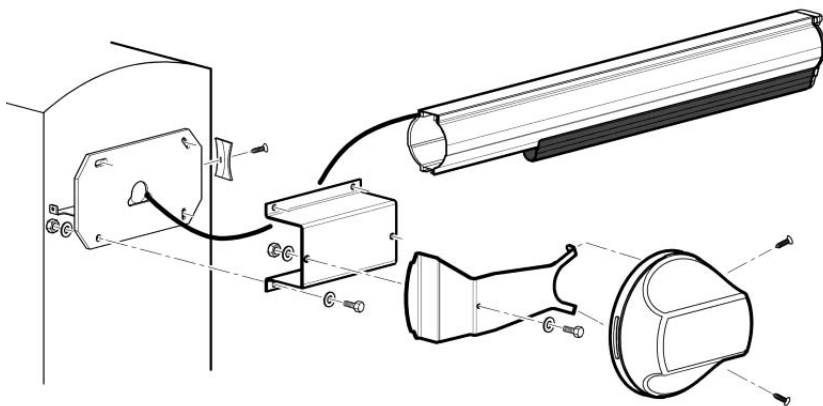

3

KABELFÜHRUNG IN DER SCHRANKE • POSIZIONARE IL CAVO NELLA BARRIERA • PLACING THE CABLE IN THE BARRIER

BAUM RECHTS  
BARRA DESTRA  
RIGHT ARM

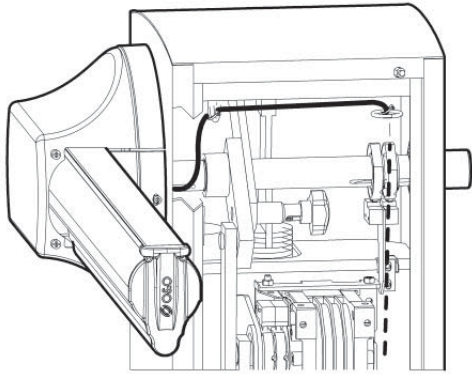

BAUM LINKS  
BARRA SINISTRA  
LEFT ARM

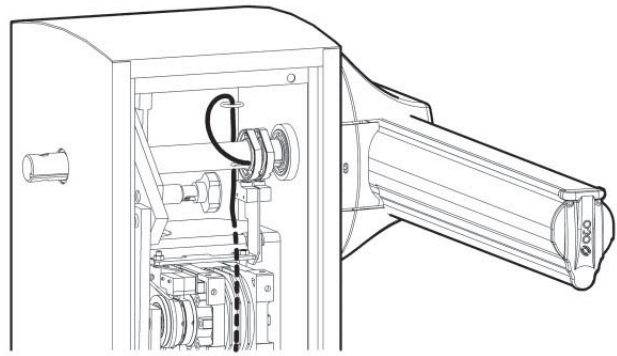

4

ELEKTRISCHER ANSCHLUSS • COLLEGAMENTI ELETTRICI • ELECTRICAL CONNECTIONS

B6000 - B7000 - B8000

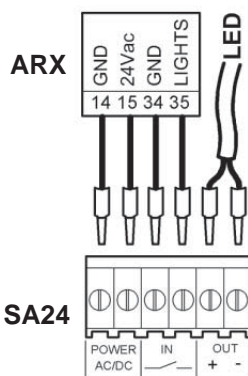
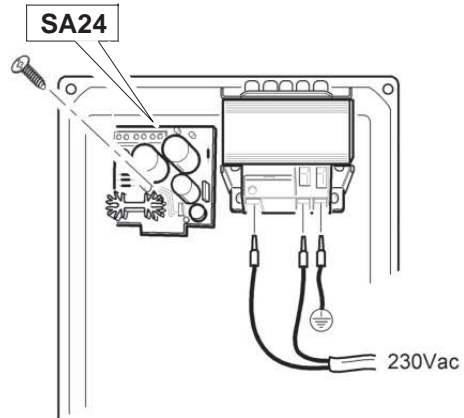
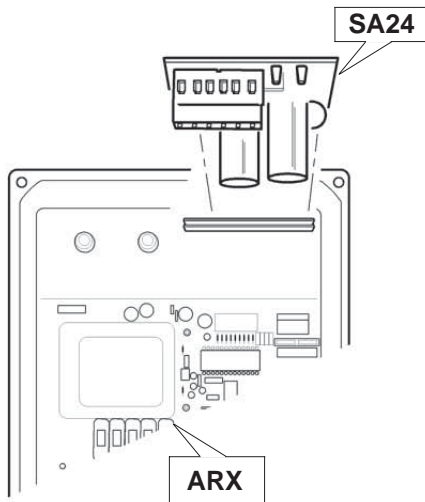

Leuchtet die LED-Streifen nicht, die Anschlussdrähte an out +/- tauschen

Nel caso le luci non si accendano invertire le connessioni out +/-

In case of light-off, invert the out +/- connection



- **WARNUNG!** Bei allen Arbeiten an der Anlage ist die Netzspannung zu abzuschalten.
- **PERICOLO!** Prima di effettuare qualsiasi intervento sull'impianto togliere l'alimentazione elettrica.
- **DANGER!** Always disconnect the electricity before attempting any work on the system.